





















MODEL NO	A	B	C	D	E	F	G	H	J	K	L	M	N	P	R	S	T	U	V	W	X	Y	Z	AA	BB	CC	DD	EE	FF	GG	HH	JJ	**FA FILTER QUANTITY	**FA FILTER/HOOD QUANTITY	**RA FILTER QUANTITY
222M	100	146	58	8.5	46.5	2	140	14.13	27.5	19.5	77	27.5	46.75	140.25	69.5	76	26	10	27.75	77.25	27.75	33.75	10	13.5	5.75	123.75	5.75	13.75	124	140.25	44.75	30	(20)20"x25"8(8)16"x25"	(2)120"x25"	(2)120"x25"
225M	100	146	58	8.5	46.5	2	140	15.38	31.5	15.5	88	31.5	46.75	140.25	69.5	76	26	10	31.75	88.25	31.75	37.75	10	13.5	5.75	123.75	5.75	13.75	124	140.25	44.75	30	(20)20"x25"8(8)16"x25"	(2)120"x25"	(2)120"x25"
227M	100	156	66	10.5	52.5	2	152	17	34.5	19.5	96	34.5	52.75	152.25	64	72	27	10	34.75	96.25	34.75	40	10	15.5	5.75	133.75	5.75	15.75	134	152.25	50.75	30	(30)20"x25"8(10)16"x25"	-	(24)20"x25"8(8)16"x25"
230M	100	156	66	10.5	52.5	2	152	18.5	37	15.5	104	37	52.75	152.25	64	72	27	10	37.25	104.25	37.25	43	10	15.5	5.75	133.75	5.75	15.75	135	152.25	50.75	30	(30)20"x25"8(10)16"x25"	-	(24)20"x25"8(8)16"x25"

Rev 06/25/14
30400075

-  80/20 BURNER PROFILE
-  TWIN FC DWDI BLOWERS
-  LIFT-OFF INTAKE FILTER SERVICE DOOR
-  DAMPER MOTOR
-  GAS CONNECTION
-  ELEC/MANIFOLD CONTROLS VESTIBULE
-  HINGED SERVICE DOOR
-  MAIN DISCONNECT SWITCH
-  LIFTING LUG (4-PLACES)
-  SUPPLY FAN BLOWER MOTOR

-  STANDARD FRESH AIR INTAKE HOOD/HOOD/FILTER COMBINATION (FILTERS SUPPLIED ONLY WHEN ORDERED)
-  FRESH AIR INTAKE FILTER
-  FRESH AIR INTAKE DAMPER
-  FRESH AIR INTAKE OPENING
-  RETURN AIR INTAKE OPENING
-  DISCHARGE DAMPER
-  DISCHARGE DIFFUSER (2-PIECES)
-  RETURN AIR INTAKE FILTER
-  RETURN AIR INTAKE FILTER SCREEN
-  HOOD SUPPORT LEGS

NOTES:

- 18/20 HAS A SINGLE VESTIBULE DOOR
- EQUIPMENT SUPPORT RECOMMENDED UNDER FRESH AIR INTAKE FILTER
- EQUIPMENT SUPPORT RECOMMENDED UNDER FRESH AIR INTAKE HOOD
- CRADLE SUPPORT RECOMMENDED UNDER RETURN AIR INTAKE FILTER
- BASE DESIGNED FOR FLAT MOUNT OR CURB MOUNT
- ALL DIMENSIONS ARE SHOWN IN INCHES
- **FA : FRESH AIR
- **RA : RETURN AIR

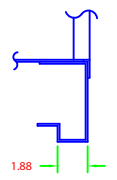

TYPICAL BASE DETAIL

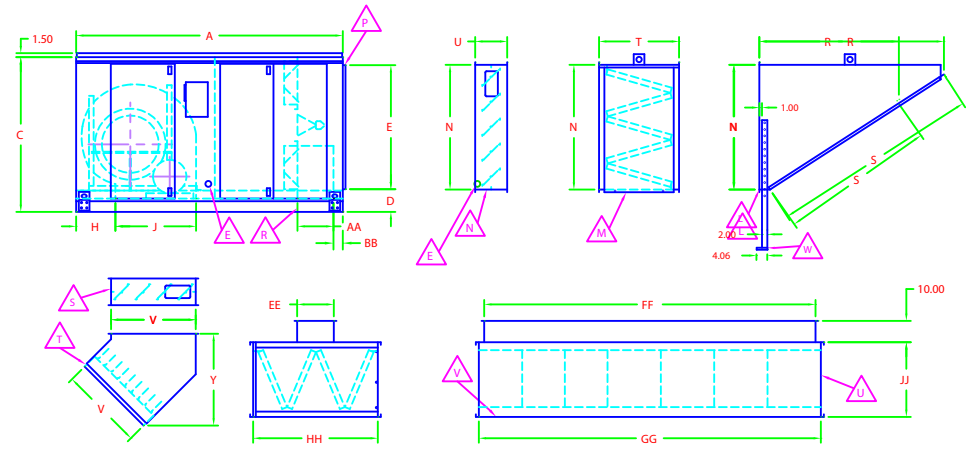
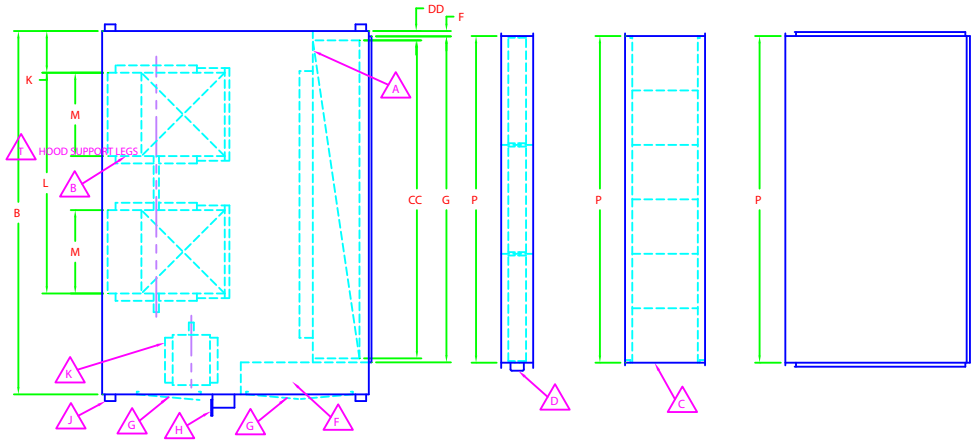
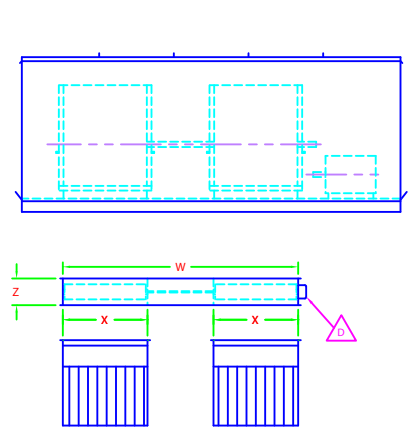

HM22230DDRL

REV	DATE	TOLERANCES
1	6-25-14	2-PLCS ±.03
2		3-PLCS ±0.15

DESCRIPTION	REVISION DESCRIPTION
	HORIZONTAL-222M, 225M, 227M AND 230M DOWN DISCHARGE RIGHT TO LEFT

DRAWN BY	TKL
DATE	07/10/00
APPROVED BY	
DATE	

RUPP AIR
MANAGEMENT SYSTEMS

SCALE: _____

DO NOT SCALE DRAWING USE DIMENSIONS SHOWN
ALL DIMENSIONS ARE IN INCHES UNLESS OTHERWISE SPECIFIED

DRAWING/PART NUMBER:
HM22230DDRL